

# INSTRUCTION MANUAL WITH PICTORIALIZED PARTS LIST

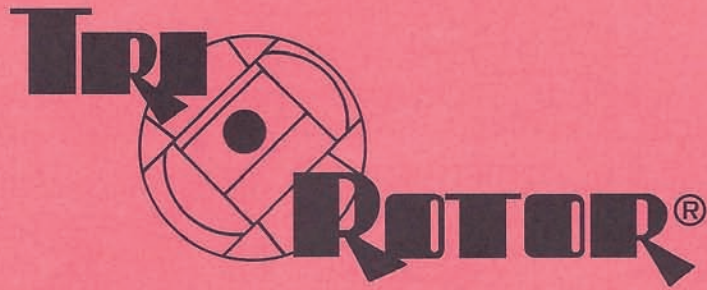

## SERIES 80

Positive Displacement Rotary Piston Pumps

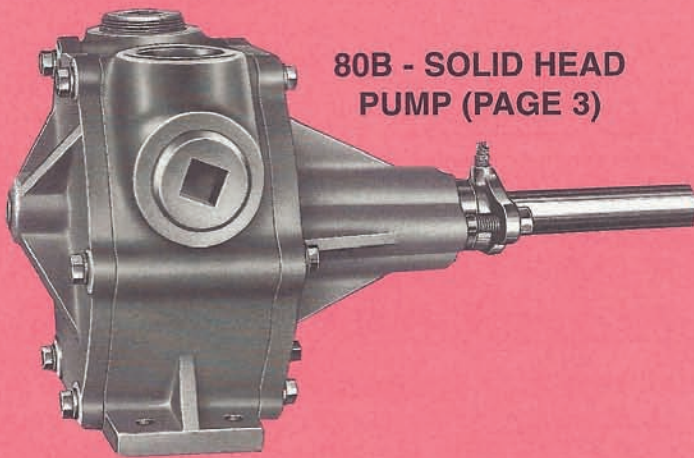

**80B - SOLID HEAD  
PUMP (PAGE 3)**

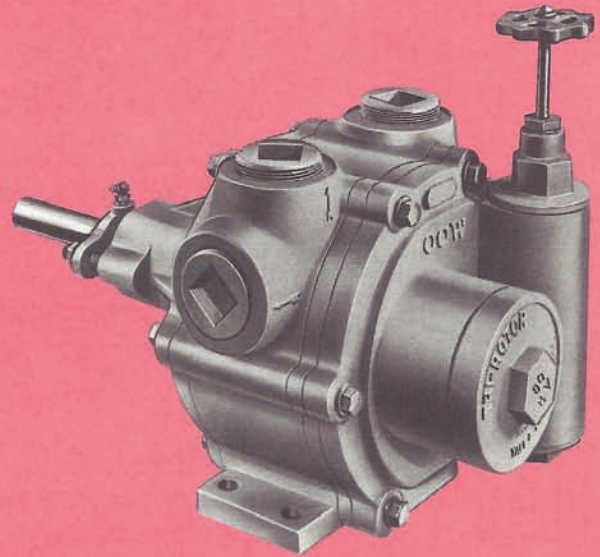

**80 BV - VARIABLE  
CONTROL HEAD  
PUMP (PAGE 2)**

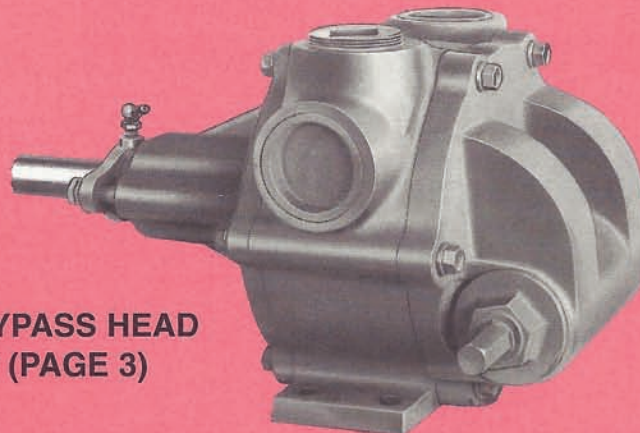

**80BX - BYPASS HEAD  
PUMP (PAGE 3)**

	Page
PUTTING PUMP INTO SERVICE . . . . .	1
VISCOSITY - SPEED - GALLONAGE CHART . . . . .	4
SERIES 20 PERFORMANCE CHARTS. . . . .	4

	Page
TROUBLE SHOOTING GUIDE . . . . .	5
PICTORIALIZED PARTS LIST . . . . .	6-9
TRI-ROTOR PUMPING PRINCIPLE . . . . .	Back Cover





Toll Free: 800-782-4477 • 860-482-8581  
 Fax: 860-482-8435  
 Email: info@trirotor.com  
 www.trirotor.com

A	2-1-67	CHANGED TO 15-1/4"
B	4-3-70	CHANGED TO 15-1/4"
C	MFC	14" OPEN AS SHOWN
D	VFC	16" OPEN NOT SHOWN

**80BV** THIS DIMEN. APPLIES TO VARIABLE HEAD

**80BX** THIS DIMEN. APPLIES TO BYPASS HEAD

**80B** THIS DIMEN. APPLIES TO SOLID HEAD

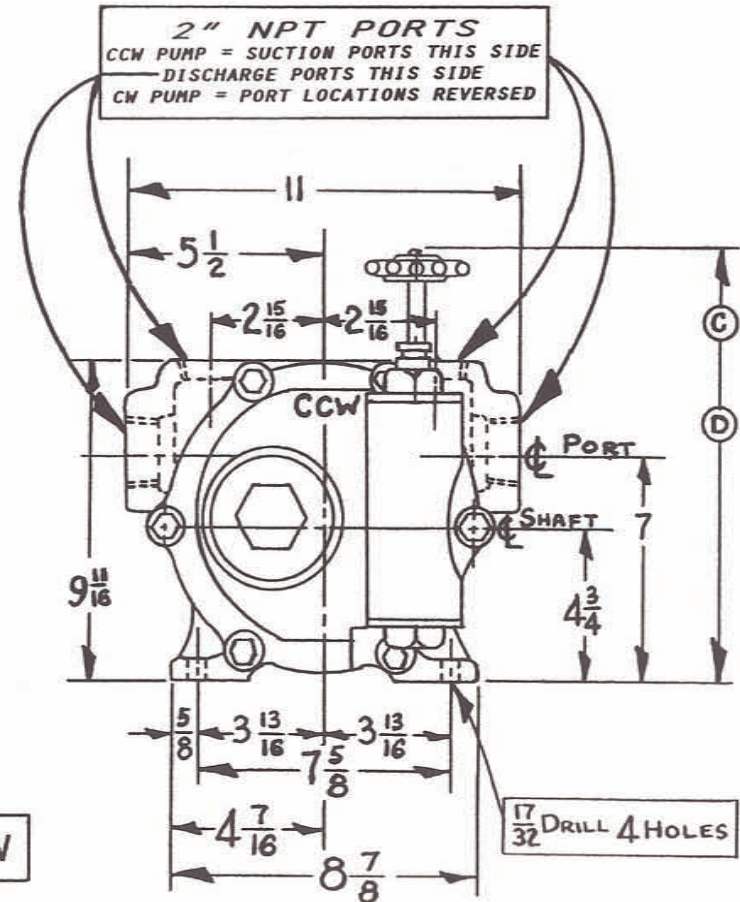
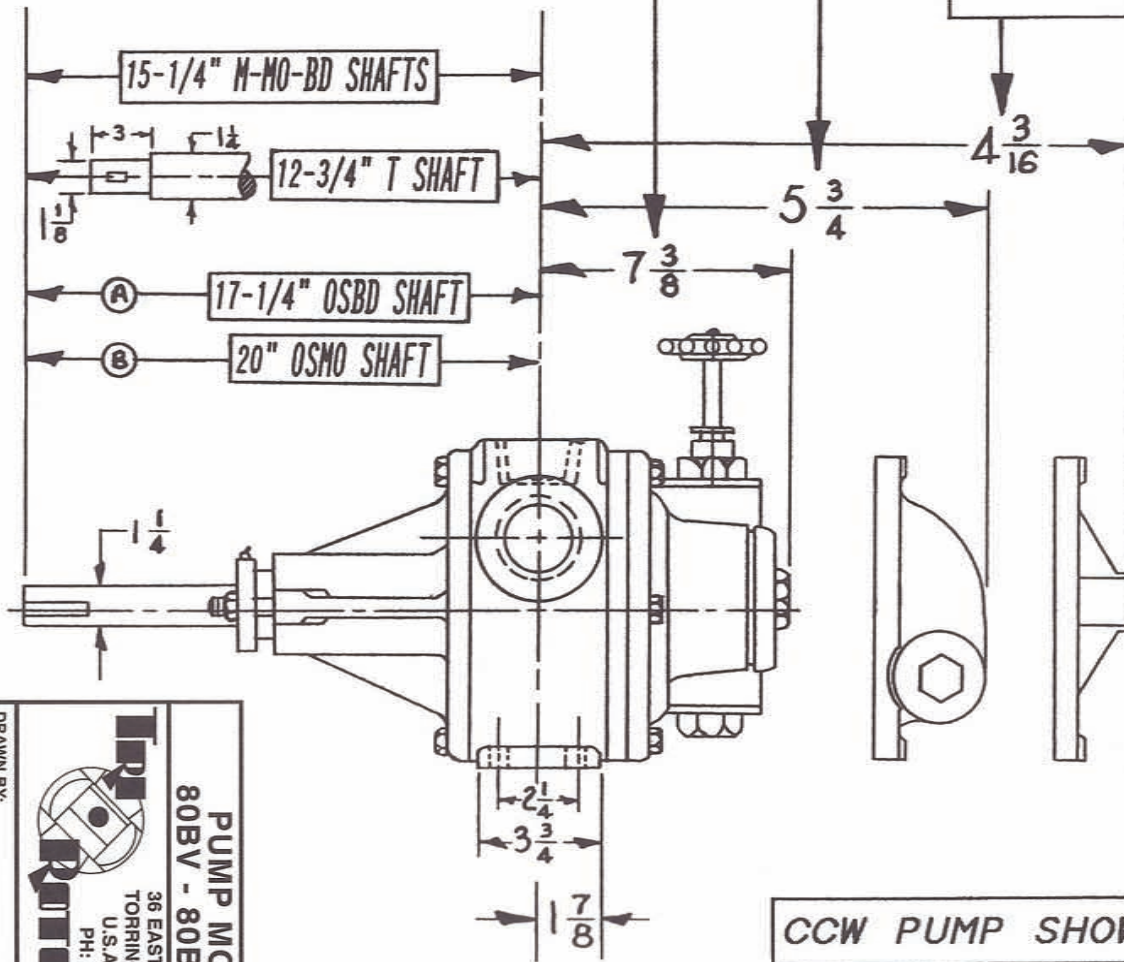

CCW PUMP SHOWN

DRAWN BY: [Signature]  
 APPROVED BY: [Signature]

**PUMP MODELS**  
 80BV - 80BX - 80B

36 EAST LAWTON STREET  
 TORRINGTON, CONNECTICUT  
 U.S.A.  
 PH: 860.482.8581 FX: 8435

J6015





Toll Free: 800-782-4477 • 860-482-8581 • Fax: 860-482-8435  
Email: info@trirotor.com • www.trirotor.com

## SERIES 80 PUMPS

MODEL **80BV** VARIABLE VOLUME PUMP, **80BX** BYPASS HEAD PUMP, **80B** SOLID HEAD PUMP  
RATED 80 GPM @ 540 RPM (MAXIMUM RATING 88 GPM @ 600 RPM)

### PUTTING PUMP INTO SERVICE

**CAUTION:** When receiving a pump, carefully check for damage, broken port seals, and misalignment incurred during shipping.

**CORRECT PIPING HOOK-UP:** The Series 80 pump comes with four 2" N.P.T. ports designed for use with Schedule 40 steel pipe. Connect piping based on direction of shaft rotation.

**SERIES 80 CW (CLOCKWISE)** rotation pump has two suction ports on right side and two discharge ports on left side (VIEWED WITH SHAFT END TOWARDS YOU), and indicated by arrows cast into body.

**SERIES 80 CCW (COUNTER CLOCKWISE)** rotation pump has two suction ports on left side and two discharge ports on right side.

- Any pump may be run in reverse temporarily for such purposes as stripping lines etc.

**WARNING: CAVITATION COULD ENSUE**

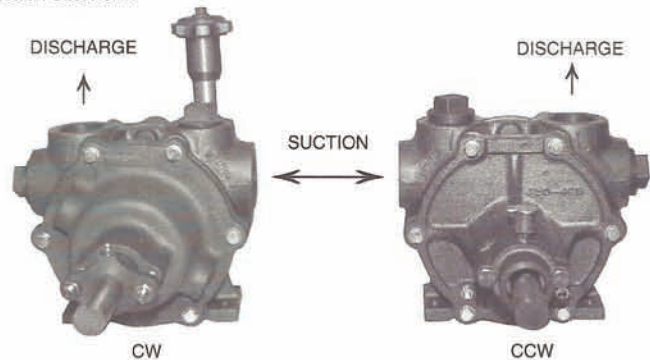

### MOUNTING AND ALIGNMENT

The following will cause misalignment:

- (1) Warped base plate (correct by shimming pump and drive components)
- (2) Pipe strain (correct by using hangers or appropriate pipe supports)

If pump is connected to drive member by couplings, shim components until coupling halves are aligned.

To prevent misalignment of pump and drive components, fasten base securely in place using the foundation bolt holes provided.

- **SHAFT SHOULD ALWAYS BE TURNABLE BY HAND**
- As a last check before starting pump: remove gland nuts and slide packing gland out of housing. If gland does not slide back into housing without interference, pump and drive shafts are misaligned.

**DIRECT MOTOR DRIVE "(M and SM)" UNITS AND GEAR DRIVEN "(GR)" UNITS:** Abutting shafts must be at least 1/8 of an inch apart and coupling inserts and/or chains should be loose enough to prevent end thrust on pump shaft. We recommend couplings with metal inserts, not rubber or plastic.

**BELT DRIVEN "(BD)" UNITS AND OPEN GEAR "(MO)" UNITS:** An outboard bearing must be used to prevent side thrust on pump shaft. Pump shaft must be free to slide longitudinally through outboard bearing, so that rotor group will not be forced against pump case components. For BD units, align sheaves using straight edge or stretched cord. For MO units, proper alignment and engagement of gear and pinion can be checked by passing foil or cellophane through them. **CAUTION:** Use gear and pinion set of same pressure angle else fibre motor pinion life will be short.

**NOTE: WE ARE NOT RESPONSIBLE FOR ANY ITEM NOT OF OUR MANUFACTURE.**

### PACKING GLAND

The packing gland serves a dual function; first as packing follower and second as a bearing which, with the shaft housing bushing, forms a support for the rotor and shaft. As shipped from the factory the gland is **LOOSE ENOUGH TO BE ROCKED BY HAND**. At first start-up **DO NOT** tighten gland until pump has run long enough for packing to expand from absorption of pumpage. Thereafter, to adjust, tighten nuts evenly one-quarter turn at a time and adjust enough to reduce leakage - **NO MORE** - a drop or two of the pumpage should normally drip from the gland every few minutes (except of course with mechanical seals, or external scavenging systems). **SHAFT SHOULD ALWAYS BE TURNABLE BY HAND. LUBRICATE SHAFT, THROUGH FITTING PROVIDED, WHILE PUMP IS UNDER OPERATING PRESSURE A MINIMUM OF EVERY 8 HOURS DURING NORMAL OPERATION.** This applies for pumps with Zero Leak Packings or Mechanical Seals to prevent forcing the lubricant back through the packing or seal. For pumps with Food Grade Packing, use only FDA approved lubricant.





Toll Free: 800-782-4477 • 860-482-8581 • Fax: 860-482-8435  
Email: info@trirotor.com • www.trirotor.com

## VARIABLE CONTROL HEAD MODEL 80BV

The Variable Volume Control Head mounted on a standard Tri-Rotor pump body allows for both automatic and/or manual changes in the flow rate of the pump. The automatic response occurs with changes in the operating pressure of the system, causing a spring-loaded hydraulic control mechanism to adjust internally, the stroke of the pump. By using flow controls, the operator can make manual adjustments to increase or decrease the discharge rate as desired.

### MANUAL AND VERNIER FLOW CONTROLS

Two flow controls are available: the Manual Flow Control (MFC) for rough adjustments, or Vernier Flow Control (VFC) which is graduated for fine setting and metering. These enable the operator to vary the discharge rate infinitely from 100% down to zero without stopping the pump or changing speed. The plunger under the control stem and control lever assembly, fix the stroke length, i.e. displacement of the pistons.

### TO ADJUST CONTROL SPRING TENSION (3 STEPS)

**STEP 1 – STOP PUMP.** Unscrew lettered spring cap and insert spring adjusting wrench as shown. Pull wrench toward “increase” and remove pawl pin. **DO NOT LET WRENCH GET AWAY.** NOTE alignment of holes between pawl plate and underlying top spring plate. Unwind to release spring tension, counting number of top spring plate holes passing hole originally containing pawl pin.

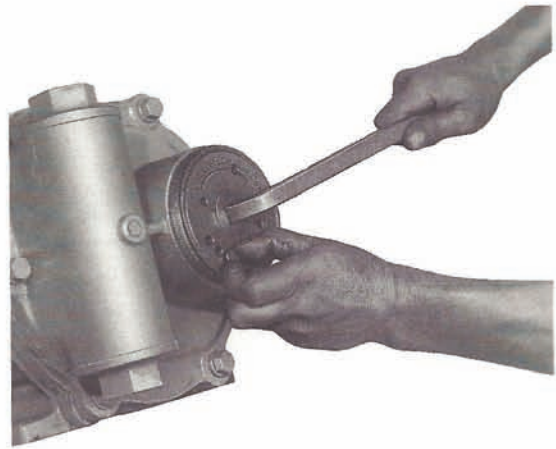

**STEP 2 –** To reset, pull wrench in direction of “increase” (note arrows on plate) until the spring begins to tighten against the control lever assembly. Note first coinciding set of holes. Thereafter, continue turning wrench, **DO NOT LET WRENCH GET AWAY**, until third top spring plate hole is seen. Insert pawl pin to lock top spring plate in this position. Pump will now develop approximately 35 PSI when running against a closed discharge line.

**STEP 3 –** For greater pressure, turn wrench to higher hole position. With standard spring, each hole represents 10 PSI, **DO NOT EXCEED 5 holes.** Heavy duty spring gives 15 PSI per hole, **DO NOT EXCEED 7 holes.**

**CAUTION:** Spring adjusting wrench is designed to bend if operator exceeds the allowable tension.

### TO REVERSE DIRECTION OF ROTATION (6 STEPS)

**CAUTION:** After reversing rotation Variable head no longer automatically reduces discharge rate. A relief valve should be installed in the discharge line. For automatic operation, order a head of opposite rotation from the factory.

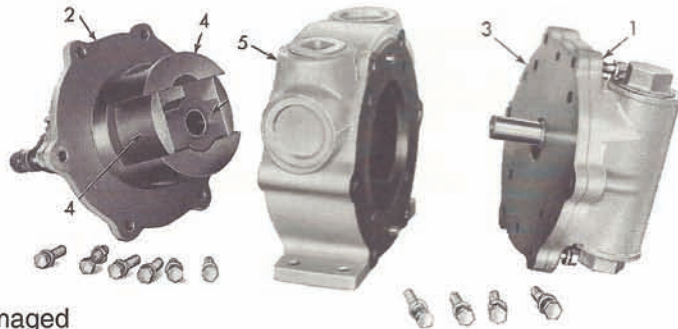

**STEP (A) –** Release spring tension as described above.

**STEP (B) –** Unbolt control head (1) and remove together with pressure control plate (3) and gaskets as one unit (pictured). Make sure gaskets are not damaged

**STEP (C) –** Unbolt shaft housing (2) and remove together with rotor group and gasket as one unit.

**THIS LEAVES PUMP IN THREE SECTIONS AS PICTURED.**

**STEP (D) –** Turn body (5) “about face” and switch dowel pins.

**STEP (E) –** Bolt the three sections back together, making sure the shuttle pin enters the bore of the shuttle.

**STEP (F) –** Reverse the wiring to run motor in opposite direction.





Toll Free: 800-782-4477 • 860-482-8581 • Fax: 860-482-8435  
 Email: info@trirotor.com • www.trirotor.com

## BYPASS HEAD MODEL 80BX

This Tri-Rotor pump model has an integral dash pot relief valve in head. The standard spring can be set up to 65 PSI at which setting it will bypass full volume; the heavy duty spring can be set up to 100 PSI.

### TO ADJUST BYPASS RELIEF PRESSURE

Remove hexagonal cap (A) and loosen locknut. Turn adjusting screw (B) in to increase pressure and out to decrease pressure. With:

**Standard Spring, #J324, (Min. 10 PSI/Max. 65 PSI).**

Each full turn represents approx. 3 PSI. **Do not exceed 17 total turns.**

**Heavy Duty Spring, #J531, (Min. 20 PSI/Max. 100 PSI).**

Each full turn represents approx. 8 PSI. **Do not exceed 12 total turns.**

**Extra Heavy Duty Spring, #J6152, (Min. 40 PSI/Max. 145 PSI).**

Each full turn represents approx. 15 PSI. **Do not exceed 8 total turns.**

Tighten locknut and replace hexagonal cap, making sure J328 gaskets are in place.

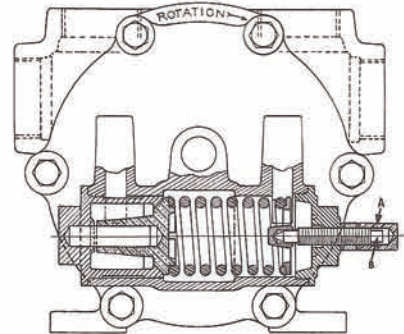

### TO REVERSE DIRECTION OF ROTATION 80BX (6 STEPS)

**STEP 1:** Unbolt bypass head and remove with bypass head gasket as one unit, making sure gasket is not damaged.

**STEP 2:** Unbolt shaft housing and remove together with rotor group and gasket as one unit.

**THIS LEAVES PUMP IN THREE SECTIONS AS PICTURED.**

**STEP 3:** Turn body "about face" and switch dowel pins.

**STEP 4:** Bolt the three sections back together, making sure the shuttle pin enters the bore of the shuttle.

**STEP 5:** To reverse bypass head components – release spring tension as described above. Remove valve cage with valve and remove end cap with spring and adjusting parts. Exchange to opposite sides of head and reassemble.

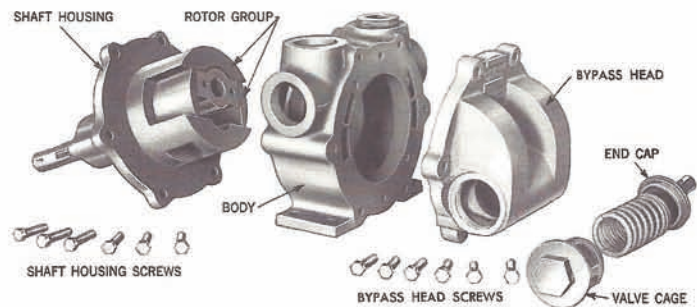

**NOTE: SPRING ADJUSTING SCREW MUST ALWAYS BE ON SUCTION SIDE OF PUMP.**

Be sure spring is centered on valve and adjusting plate.

**STEP 6:** Reverse wiring to run motor in opposite direction.

## SOLID HEAD MODEL 80B

The model **80B** has a solid head with the shuttle pin set in a fixed position to give constant volume for simple transfer service. A RELIEF VALVE SHOULD BE INSTALLED IN THE DISCHARGE LINE FOR PROTECTION.

### TO REVERSE DIRECTION OF ROTATION 80B (5 STEPS)

**STEP 1:** Unbolt solid head and remove with head gasket as one unit, making sure gasket is not damaged.

**STEP 2:** Unbolt shaft housing and remove together with rotor group and gasket as one unit.

**THIS LEAVES PUMP IN THREE SECTIONS AS PICTURED.**

**STEP 3:** Turn body "about face" and switch dowel pins.

**STEP 4:** Bolt the three sections back together, making sure the shuttle pin enters the bore of the shuttle.

**STEP 5:** Reverse wiring to run motor in opposite direction.

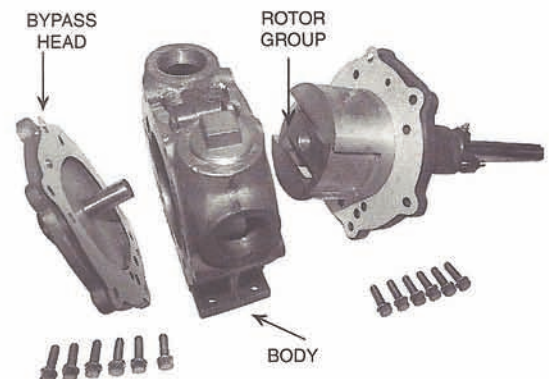





# SERIES 80 PUMPS

RATED 80 G.P.M.

@540 R.P.M.

Toll Free: 800-782-4477 • 860-482-8581

Fax: 860-482-8435

Email: info@trirotor.com

www.trirotor.com

## MAXIMUM RECOMMENDED PUMP SPEEDS FOR VARIOUS VISCOSITIES

SERIES 80			
Rating	80 GPM @ 540		
Displacement Factor	14.8 Gals/100 Revs.		
Port Size	Four 2" x 11-1/2 THD NPT		
SSU / CPS	RPM	GPM	Suct.
40 / 4	600	88	2
100 / 20	600	88	2
400 / 78	590	87	2
600 / 125	588	86	2
800 / 165	570	84	2
1,000 / 200	560	83	2
1,600 / 335	540	80	2 1/2
2,000 / 410	530	79	2 1/2
3,000 / 620	510	75	2 1/2
5,000 / 1,060	470	70	2 1/2
8,000 / 1,700	440	65	2 1/2
9,000 / 1,900	420	62	2 1/2

For Viscosities Below, Pump Must Have Relieved Rotor Group (For Sticky, Tacky Fluids)

Port Size	Four 2" x 11-1/2 THD NPT		
10,000 / 2,150	410	61	3
15,000 / 3,100	370	55	3
20,000 / 4,250	330	49	3
30,000 / 6,500	280	41	4
40,000 / 8,610	230	34	4
50,000 / 10,800	190	28	4
75,000 / 16,210	130	19	4
100,000 / 21,625	100	15	4

GENERAL RULE: Viscous fluids which retain their "slipperiness" or which readily thin out with slight temperature increase or agitation do not require a relieved rotor group.

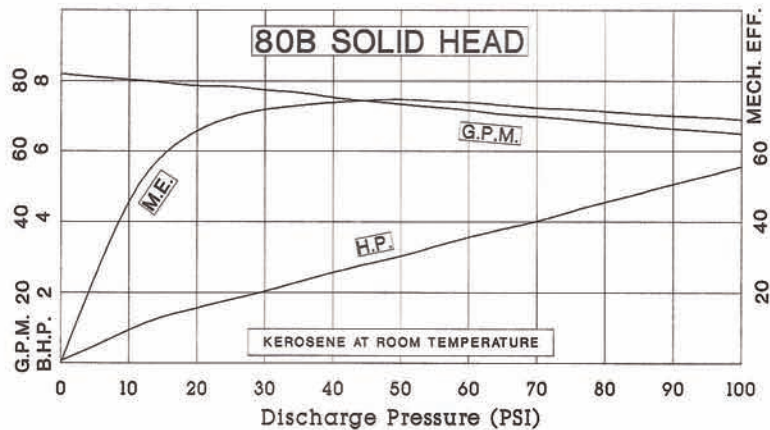
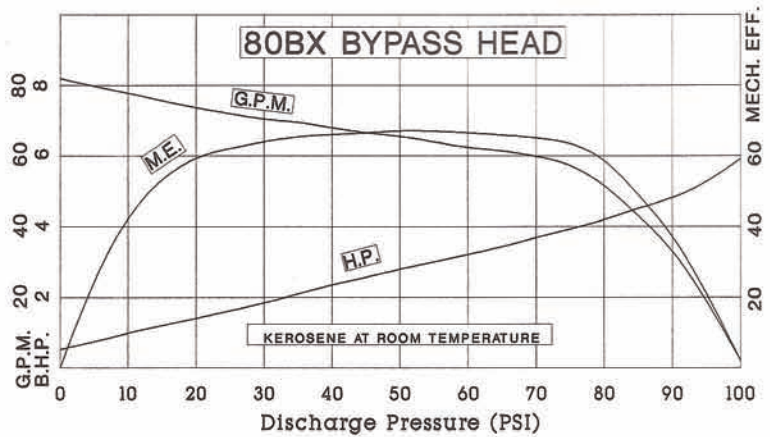
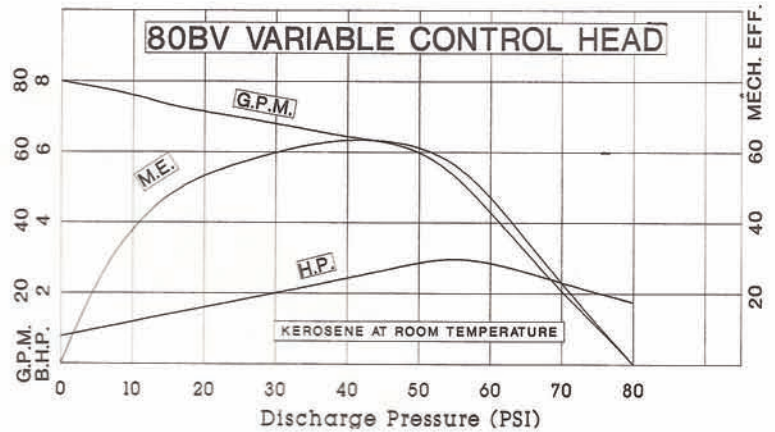

**CAUTION:** Suction piping diameter and length must be separately determined, regardless of pump port size, where (1) volatile liquids or (2) viscous pumpages are concerned. The sizes shown in the above chart are for suction lines no longer than 10 feet and containing no more than 2 pipe fittings.





## TROUBLESHOOTING GUIDE

TROUBLE	TYPE OF PUMP			LOOK FOR
	VARIABLE HEAD	BYPASS HEAD	SOLID HEAD	
<b>N O  F L O W</b>	●	●	●	CW PUMP RUNNING CCW, OR VICE VERSA (1)* MOTOR WIRING REVERSED PIPING TO WRONG PORTS
	●	●	●	DISCHARGE HEAD TOO HIGH PIPING TOO SMALL, TOO LONG (4) VISCOSITY TOO HIGH (4)
	●			FLOW CONTROL TURNED DOWN TO ZERO
	●			PAWL PIN MISSING (2) CONTROL SPRING (2) - not adjusted - wound backwards - distorted - broken out of top or bottom spring plate
		●		RELIEF VALVE SPRING - not adjusted (3) - not in correct position (3) - spring broken
	●			PLUNGER FROZEN IN BOTTOM POSITION - corroded parts - pumpage shear sensitive - dirt accumulation preventing movement
		●		RELIEF VALVE - not fully seated (3) - stuck on valve guide pin - need lapping into seat - spring adjusting plate missing
	●	●	●	INADEQUATE PRIMING CONDITIONS SUCH AS - suction line air leak - foot valve stuck - lift too great - altitude too high - vapor lock
	●	●	●	ROTOR GROUP WORN / MECHANICAL SEAL WORN OR BROKEN
CAVITATING VIBRATING HIGH AMP. DRAIN	●	●	●	STARVED SUCTION LINE DUE TO - suction line restricted - viscosity too great for piping - RPM too high for viscosity (4)
PUMP RUNNING HOT	●	●	●	PACKING TOO TIGHT (1) MISALIGNED PUMP (1) INSUFFICIENT LUBRICATION OF SHAFT (1)
	●	●		TOO LONG RUNNING IN FULL BYPASS CYCLE OR ZERO STROKE
	●	●	●	OVERSPEEDING (4) CAVITATION
PUMP FROZEN CAN'T TURN SHAFT	●	●	●	PACKING TOO TIGHT (1) MISALIGNMENT (1) OBSTRUCTION IN ROTOR GROUP - rotor group part broken RUSTED PARTS- blush rust causing parts to seize together
	●	●	●	PUMPAGE - shear sensitive - congealed - caramelized - solidified TEMPERATURE OF ALL BRONZE OR BRONZE FITTED PUMP EXCEEDING 140° F ROTOR GROUP NOT RELIEVED
NOISY PUMP	●	●	●	CAVITATION WORN ROTOR GROUP AIR LEAK INTO SUCTION LINE
	●	●		PLUNGER OR VALVE BOUNCING DUE TO - suction line restriction - relief valve in discharge line reacting with pump spring setting - PIPING RESONANCE
EXCESSIVE LEAKAGE FROM PACKING GLAND	●	●	●	PACKING NUTS INCORRECTLY ADJUSTED PACKING WORN MECHANICAL SHAFT SEAL WORN OR BROKEN SHAFT SCORED
REDUCTION OF FLOW OR PRESSURE	●			PAWL PIN BROKEN CONTROL SPRING SETTING INCORRECT (2) CONTROL PLUNGER STUCK (2)
		●		BYPASS SPRING SETTING INCORRECT (3) VALVE UNSEATED OR WORN (3)
	●	●	●	PUMP WORN RESTRICTION OR TOO HIGH VISCOSITY IN SUCTION LINE (4)
PREMATURE WEAR  SHORT PUMP LIFE	●	●	●	MISALIGNMENT - end or side thrust on shaft (1) PACKING TOO TIGHT OR ADJUSTED INCORRECTLY DIRTY OR ABRASIVE PUMPAGE RUNNING PUMP DRY - repeated suction lift OVERSPEEDING (4) NON-LUBRICATING PUMPAGE OPERATING ABOVE 50 PSI & 350 RPM
	●			FLOW CONTROL SET BELOW 25% CAPACITY FOR TOO LONG PERIODS SUCTION LINE RESTRICTED CAUSING PLUNGER "BOUNCE"
SCORED OR GOUGED PARTS	●	●	●	MISALIGNMENT (1) - transmittal of end thrust from motor shaft excessive belt tension - PIPE STRAIN - OVER TIGHTENING OF GLAND (1)

\* NUMBERS IN PARENTHESIS PERTAIN TO PAGE NUMBERS WHERE MORE INFORMATION CAN BE FOUND.







**WHEN ORDERING PARTS ALWAYS GIVE:**

- 1) PUMP SERIAL NUMBER
- 2) ROTATION OF PUMP (CW or CCW)
- 3) SHAFT LENGTH (from port centerline)

**INTERCHANGEABLE PARTS FOR PUMP SERIES 80**

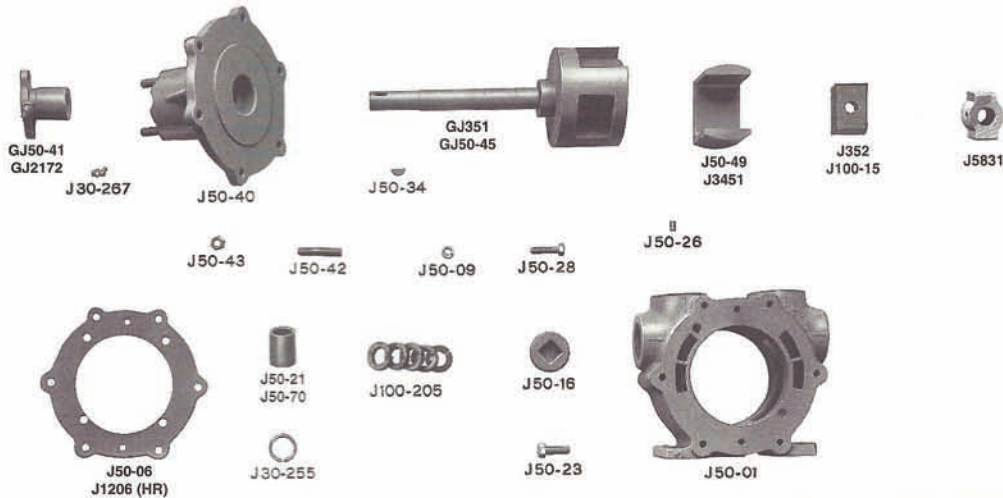

CAUTION: Part Numbers under pictured parts represent examples only. For exact identification of required part for your pump, select part number from list below.

**BODY PARTS**

Part No.	Part Name	
J30-255	Retaining Ring	
J30-267	Alemite Grease Fitting	
<b>J50-01</b>	<b>Body, 80, 2" Ports</b>	
J50-06	Body Gasket	
J50-09	Lockwasher	6/Set
J50-16	Pipe Plug	
<b>J50-21</b>	<b>Shaft Housing Bushing (Bze)</b>	
J50-23	Attaching Bolt	4/Set
J50-26	Body Dowel	2/Set
J50-28	Bolt	6/Set
GJ50-40	Shaft Housing*	
<b>GJ50-41</b>	<b>Packing Gland/Fitting (Bze)</b>	
J50-42	Gland Stud	2/Set
J50-43	Gland Stud Nut	2/Set
J100-58	Flange Bolts	8/Set
<b>J100-205</b>	<b>Standard Packing</b>	<b>5/Set</b>
J738	Food Packing	5/Set
J944	Lantern Ring	
J1719	Drain Plug	
J5975	Teflon Packing	5/Set
J6045	Teflon Composition Bushing	
J6050	Teflon Impregnated Packing	5/Set
J6114	Body, 80 (Bze) 2" Ports	
J6262	Zero Leak Packing #3	Set
J6266	Zero Leak Packing #30	Set

**ROTOR GROUP PARTS**

(See Chart below for Added Relieving Costs)

Part No.	Part Name	
<b>J50-49</b>	<b>Piston Iron</b>	
J3451	Piston Bronze	
J4666	Piston Steel	
J100-15	Shuttle Bronze	
<b>J352</b>	<b>Shuttle Iron</b>	
J3619	Shuttle Carbon	
J5713	Formed Shuttle Bronze	
J5831	Formed Shuttle Iron	
J6118	Shuttle Teflon	
J6156	Shuttle Hardened Iron	
GJ50-45	Rotor & Shaft Bronze**	
<b>GJ351</b>	<b>Rotor &amp; Shaft Iron**</b>	
GJCB351	Counterbored Rotor & Shaft Iron**	
GJAB728	Rotor & Shaft (For All Bze Pump)**	
GJI-50-33	Rotor Group Iron	T
GJB-50-33	Rotor Group Bronze	12 3/4"
GJI-100-11	Rotor Group Iron	M-MO or BD
GJB-100-11	Rotor Group Bronze	15 1/4"
GJAB-100-11	Rotor Group (For All Bze Pump)	
GJI-3447	Rotor Group Iron	Old Style
GJB-3447	Rotor Group Bronze	BD 17 1/4"
GJAB-3447	Rotor Group (For All Bze Pump)	
GJI-87	Rotor Group Iron	Old Style
GJB-87	Rotor Group Bronze	20"

**ALL IRON PARTS**

Part No.	Part Name
J50-70	Shaft Housing Bushing (Iron)
GJ2172	Packing Gland/Fitting (Iron)

**STEAM JACKETED PARTS**

Part No.	Part Name	
J1206	Body Gasket (HR)	
J1207+	Heat Packing	5/Set
GJ1851	Shaft Housing*	

**WHEN FOLLOWING PARTS ARE RELIEVED (REL), ADVISE**

- Shuttle
- Piston
- Rotor & Shaft
- Rotor Group

\* Includes Bushing, Retaining Ring and Drain Plug.  
 + For temperatures under 500° F, use J6050

\*\* Furnished with following shaft lengths: T 12 3/4", M-MO or BD 15 1/4", BD 17 1/4", MO 20".

**NOTE: ALWAYS GIVE PUMP SERIAL NUMBER WHEN ORDERING PARTS.**



- 1) PUMP SERIAL NUMBER
- 2) ROTATION OF PUMP (CW or CCW)
- 3) SHAFT LENGTH (from port centerline)

**80BV VARIABLE CONTROL HEAD PARTS**

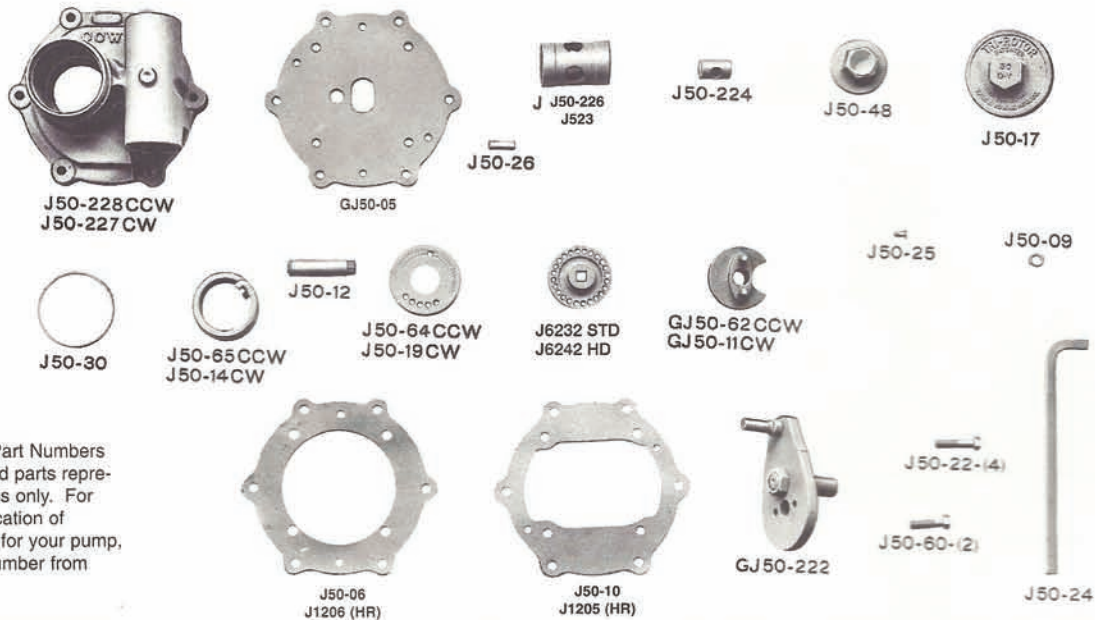

CAUTION: Part Numbers under pictured parts represent examples only. For exact identification of required part for your pump, select part number from list below.

**80BV VARIABLE CONTROL HEAD PARTS**

Part No.	Part Name	Part No.	Part Name
GJ50-05	Press. Cont. Plate w/J50-12 Pin/Advise Rotation	GJ50-222	Control Lever Assembly
J50-06	Body Gasket	J50-223	Control Lever Pin
J50-09	Lockwasher 6/Set	J50-224	Plunger Crosshead
J50-10	Variable Control Head Gasket	J50-226	Control Plunger (Bze)
GJ50-11	Bottom Spring Plate (Std) CW	J50-227	Control Head CW
J50-12	Spring Plate Pin	J50-228	Control Head CCW
J50-14	Control Spring (Std) CW 50 PSI	JAB50-228	Control Head CCW (Bze)
J50-17	Spring Cap	J518	Control Spring CCW (HD) 100 PSI
J50-19	Pawl Plate CW	J519	Control Spring CW (HD) 100 PSI
J50-22	Bolt 4/Set	J523	Control Plunger (Iron) ENP
J50-24	Spring Adjusting Wrench	GJ799	Bottom Spring Plate (HD) CW
J50-25	Pawl Pin	GJ800	Bottom Spring Plate (HD) CCW
J50-30	Spring Cap Gasket	J1031	Long Spring Plate Pin
J50-36	Shuttle Pin Nut	J1206	Body Gasket(HR)
J50-48	Control End Cap	GJ1760	Control Head Complete CW*
J50-60	Bolt 2/Set	GJ1761	Control Head Complete CCW*
GJ50-62	Bottom Spring Plate (Std) CCW	GJ1762	Control Head Complete CW/MFC*
J50-64	Pawl Plate CCW	GJ1763	Control Head Complete CCW/MFC*
J50-65	Control Spring (Std) CCW 50 PSI	J6232	Top Spring Plate CW/CCW (Std)
J50-67	Shuttle Pin	J6242	Top Spring Plate CW/CCW (HD)

**MANUAL FLOW CONTROL PARTS**

Part No.	Part Name
J502	Plunger Adjusting Screw
J503	End Cap
J505	Handwheel
GJ788	Manual Flow Control Complete
J1194	Adjusting Screw Packing 5/Set

**STEAM JACKETED PARTS**

Part No.	Part Name
JHT 519	Control Spring CW (HD) High Temp 100 PSI
J1205	Variable Control Head Gasket (HR)
J3701	Control Head, CW only
GJ3701	Control Head Complete, CW only

**VERNIER FLOW CONTROL PARTS**

Part No.	Part Name
J3709	Adjusting Screw Packing 6/set
GJ3875	Vernier Flow Control Complete

\* Advise if Standard, Heavy Duty or High Temp Spring required.

**NOTE: ALWAYS GIVE PUMP SERIAL NUMBER WHEN ORDERING PARTS.**



**WHEN ORDERING PARTS ALWAYS GIVE:**

- 1) PUMP SERIAL NUMBER
- 2) ROTATION OF PUMP (CW or CCW)
- 3) SHAFT LENGTH (from port centerline)

**BYPASS HEAD PARTS AND SOLID HEAD PARTS FOR PUMP SERIES 80**

**80 BX BYPASS HEAD PARTS**

Part No.	Part Name	
J50-09	Lockwasher	6/Set
J50-50	Shuttle Pin	
J50-229	Bolt	6/Set
GJ300	Bypass Head/Pin CW or CCW	
J321	<b>Bypass Head Gasket</b>	
J324	Valve Spring (Std) 65 PSI	
J325	Spring Adjusting Plate	
J326	Spring Adjusting Screw	
J327	Adjusting Screw End Cap	
J328	<b>Adjusting Screw Gasket</b>	2/Set
J329	Spring Adjusting Screw Cap	
J531	Valve Spring (HD) 100 PSI	
<b>GJ1838</b>	<b>Valve Cage/Pin (Iron) Std.</b>	
J1839	Valve (Iron)	
J3736	Adjusting Screw Locknut	
GJ4174	Valve Cage/Pin (Bronze)	
<b>J4175</b>	<b>Valve (Bronze) Std.</b>	
GJ4253	Bypass Head/Pin (Bze) CW or CCW	
GJ4586	Bypass Head Complete CW or CCW	
J6152	Valve Spring (Extra HD) 145 PSI **	
GJX6222	Bypass Head/offset Pin CW or CCW+	

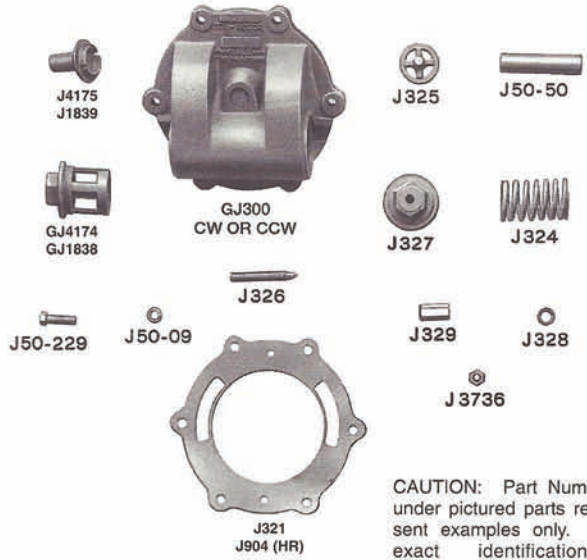

**STEAM JACKETED PARTS**

JHT531	Valve Spg, High Temp (HD) 100 PSI
J904	Bypass Head Gasket (HR)
J1701	Bypass Head/Pin CW or CCW
GJ1701	Bypass Head Complete CW or CCW*

CAUTION: Part Numbers under pictured parts represent examples only. For exact identification of required part for your pump, select part number from list below.

**80B SOLID HEAD PARTS**

Part No.	Part Name	
J50-06	<b>Solid Head Gasket</b>	
J50-09	Lockwasher	6/Set
J50-28	Bolt	6/Set
<b>GJ50-31</b>	<b>Solid Head/Pin CW or CCW</b>	
J50-50	Shuttle Pin	
GJ726	Solid Head/Pin CW or CCW (Bze)	
GJ6222	Solid Head/Offset Pin CW or CCW+	



**STEAM JACKETED PARTS**

J1206	Solid Head Gasket (HR)
GJ3360	Solid Head/Pin CW or CCW

**MISCELLANEOUS**

Part No.	Part Name
GJ335	Outboard Bearing Complete
GJ2150	Pressure Regulating Control Complete
J3997B	Mechanical Seal, Type 1, Buna
J3997V	Mechanical Seal, Type 1, Viton
GJ3998	Mechanical Seal Gland, Type 1
J6235	Mechanical Seal Stop Collar, Type 1



\* Advise if Standard, Heavy Duty, Extra Heavy Duty or High Temp Spring required.  
 \*\* Requires pump to be equipped with counterbored rotor, steel piston and formed shuttle.  
 † Specify offset pin position.

**NOTE: ALWAYS GIVE PUMP SERIAL NUMBER WHEN ORDERING PARTS.**



**Tri**  
  
**ROTOR®**  
**PUMPING PRINCIPLE**

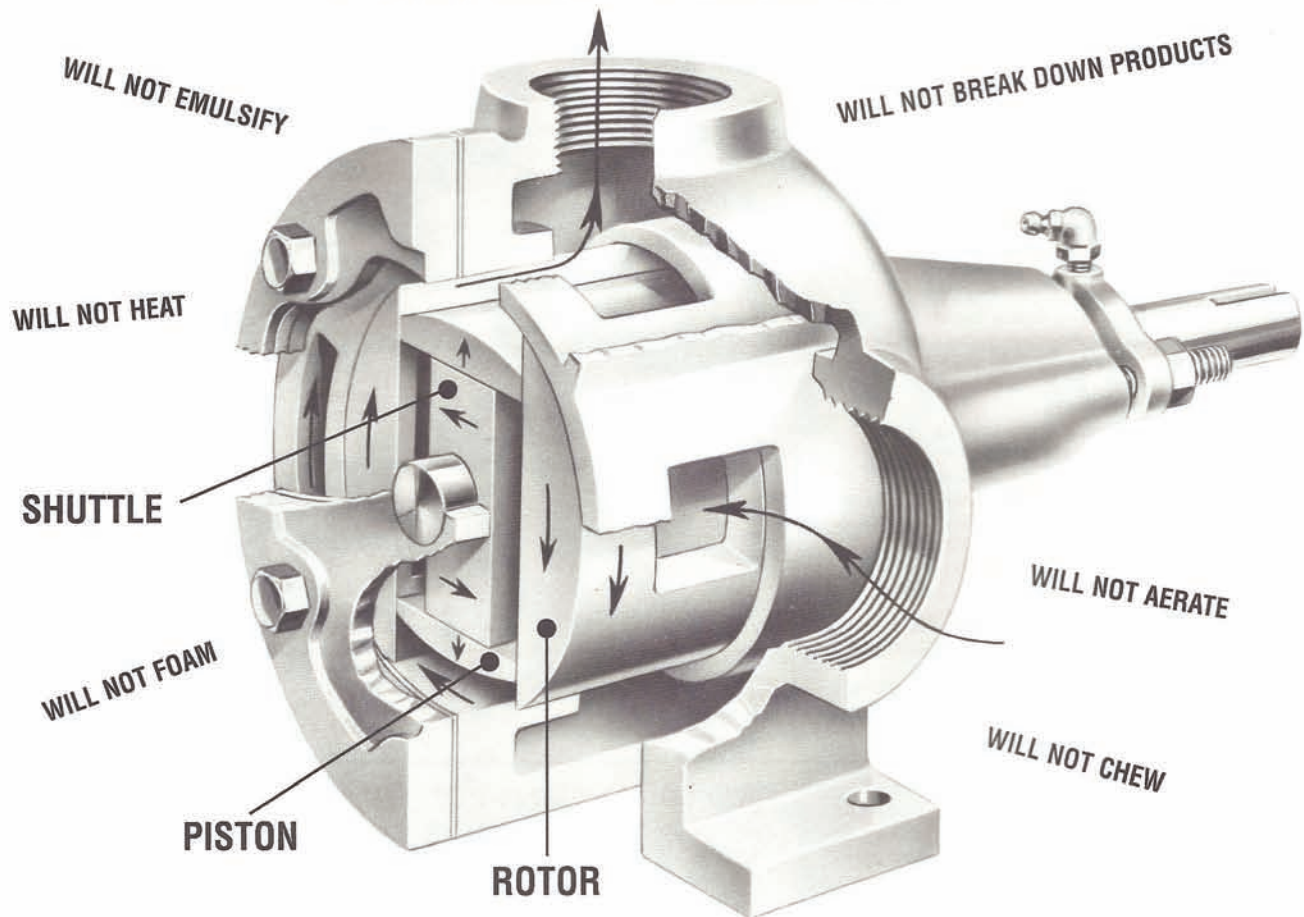

The mechanical principle of the Tri-Rotor Pump is explained as follows and incorporates the pump casing, the rotor, the piston, and the shuttle. The rotor is a liquid-tight fit within the casing, with the piston and shuttle being equally liquid-tight in their fit to each other and to the rotor. In operation, the piston slides back and forth in the rotor slot, drawing liquid from one end of the rotor slot and discharging from the opposite end. At the same time, the shuttle slides back and forth within the piston slot (picture), drawing liquid through one rotor port and discharging through the other. The rotor, which functions as a rotating valve, channels the liquid from the intake port around through the casing and out the discharge port.

This action, while rotary, actually accomplishes the same type of pumping principle as a direct-acting piston pump. There are, therefore, two direct-acting pistons pumping through two cylinders, being valved by the rotary action of the rotor.

The reciprocating piston action is accomplished by the center bearing of the shuttle which rotates on a shuttle pin eccentric to the rotor shaft. Since the rotor is concentric with the shaft and the shuttle bearing is eccentric to the shaft, a reciprocating action of the piston and shuttle within their respective cylinder slots is created by revolving the rotor. Four overlapping strokes of the piston and shuttle for each revolution of the rotor create a smooth discharge with pulsation reduced to a minimum. An extremely high volumetric efficiency is obtained because of the piston-type action and the liquid-tight fit of the moving members.

Highly viscous materials are easily handled with exceptionally high volumetric efficiency while thin, volatile materials are handled with little loss in slippage through the pumping members. Materials critical to agitation are handled with little or no mechanical beating, since the product is carried through the pump by piston action without being subjected to the combination centrifugal and gear or paddle agitation.